

Half-Cell Isolator

EZOTM Carrier Board

Data input	UART or I ² C
Voltage input	3.0V – 5.0V
Probe connector	Female SMA
Current consumption	5V 15 mA 3.3V 20 mA
Power saving mode (OFF pin)	3.8mA

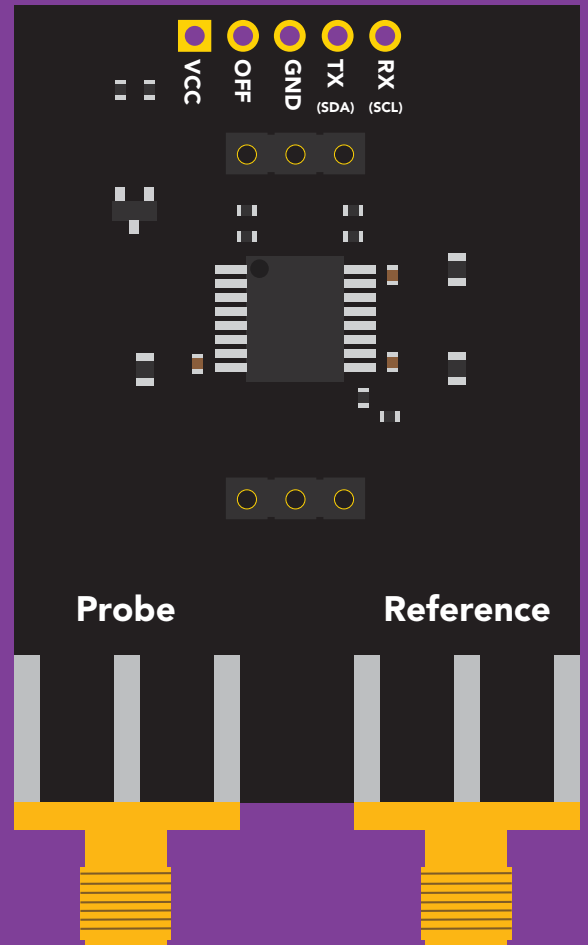

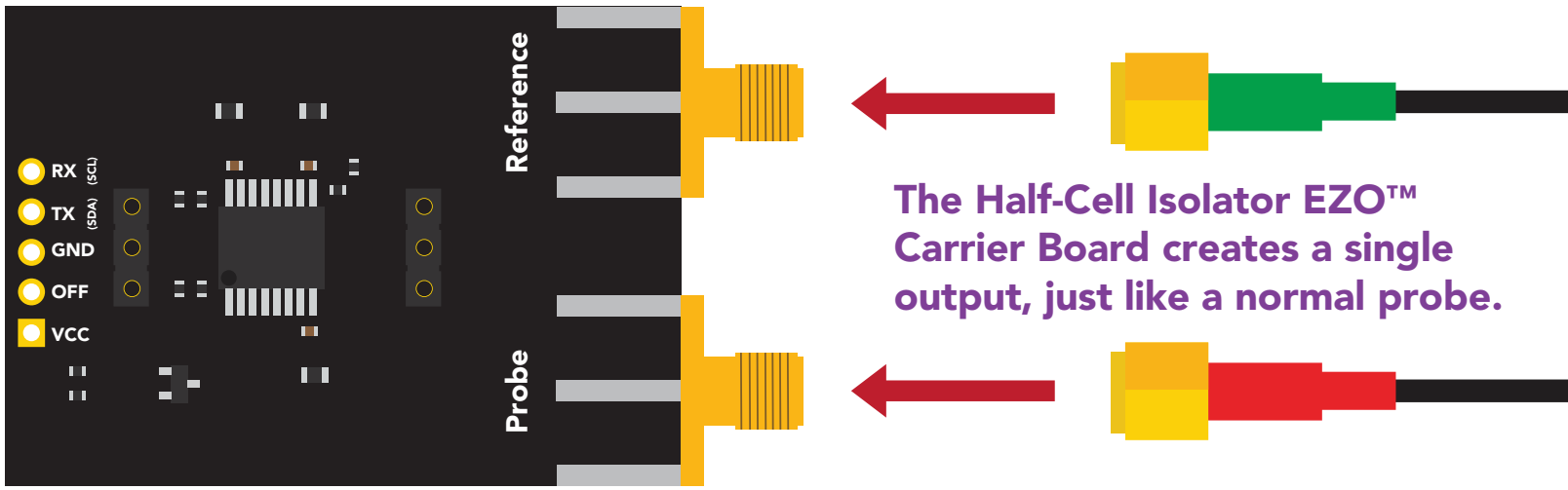

Carrier board dimensions

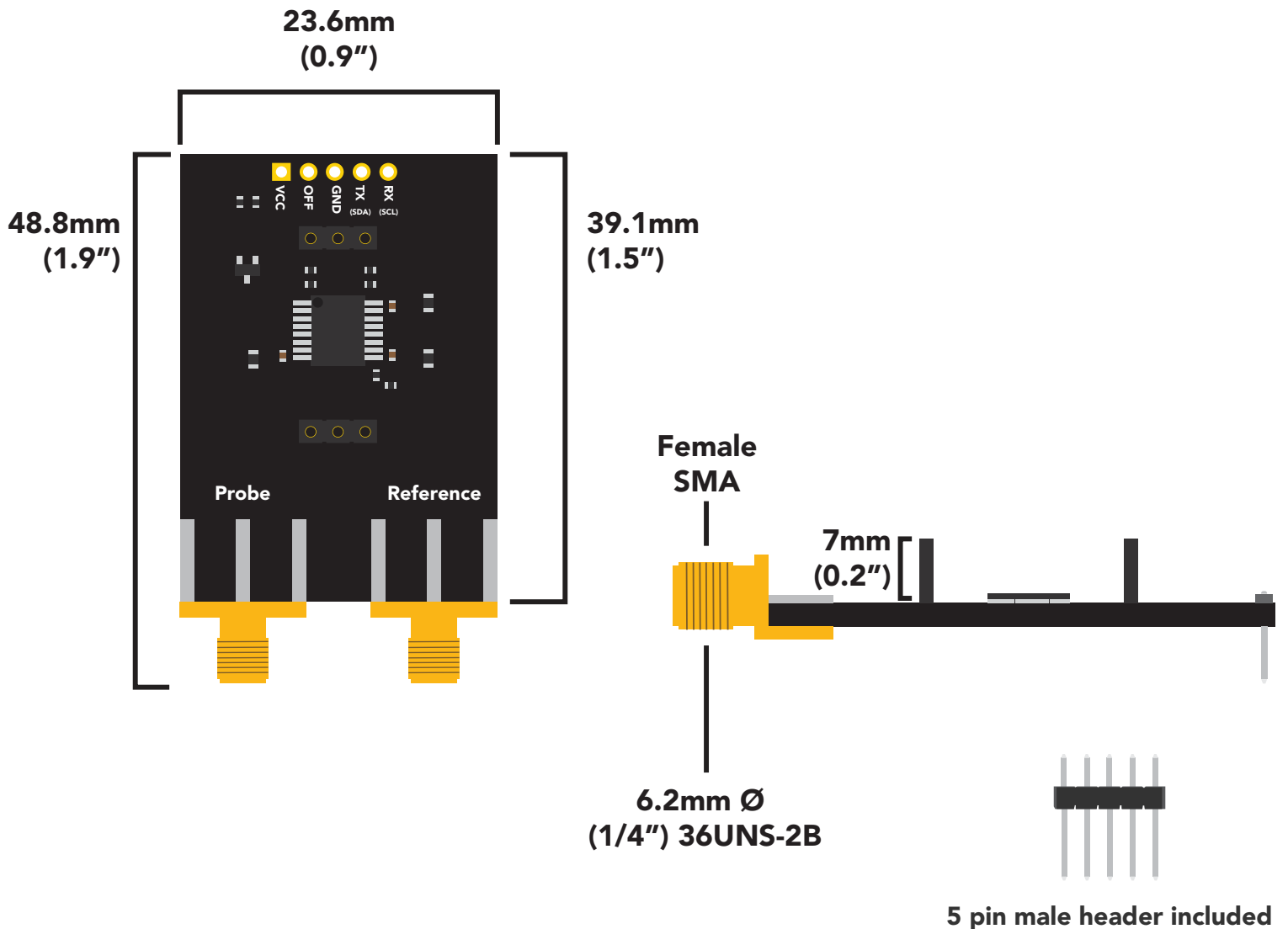

Current consumption

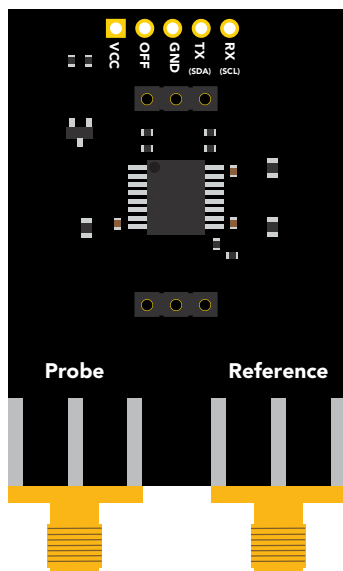

$i = 15\text{mA}$

+

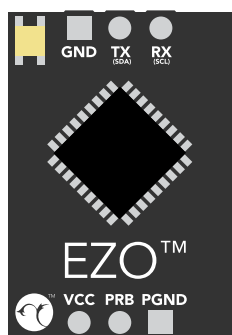

$i = X\text{mA}$

≠

$15 + X\text{mA}$

The current consumption for the Half-Cell Isolator EZO™ Carrier Board is non-linear. The table below shows how much current will be consumed when an EZO™ circuit is connected to the Half-Cell Isolator EZO™ Carrier Board.

		5V	3.3V
Half-Cell Isolator EZO™ Carrier Board	No Load	15mA	20mA
	EZO™ pH	57mA	87mA
	EZO™ ORP	58mA	84mA

Setting the OFF pin to low will turn off the Half-Cell Isolator EZO™ Carrier Board, along with the connected EZO™ circuit. The current consumption will be reduced to **3.8 mA**.

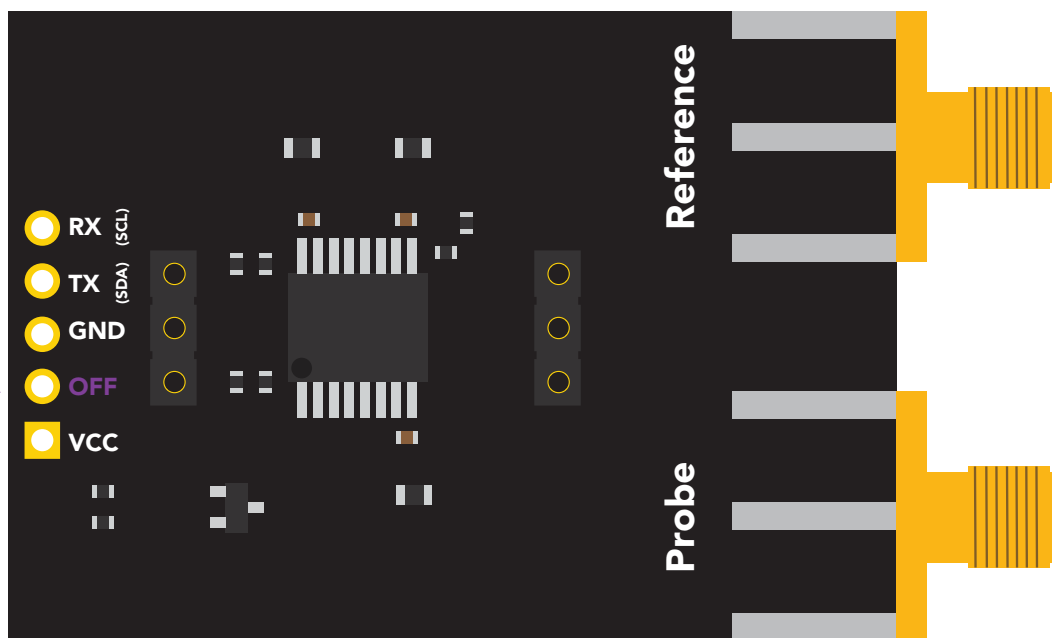

Pin out

Setting the OFF pin to low will turn off the Half-Cell Isolator EZO™ Carrier Board, along with the connected EZO™ circuit. The current consumption will be reduced to 3.8mA.

If the OFF pin is not used, leave it unconnected or pull to VCC.

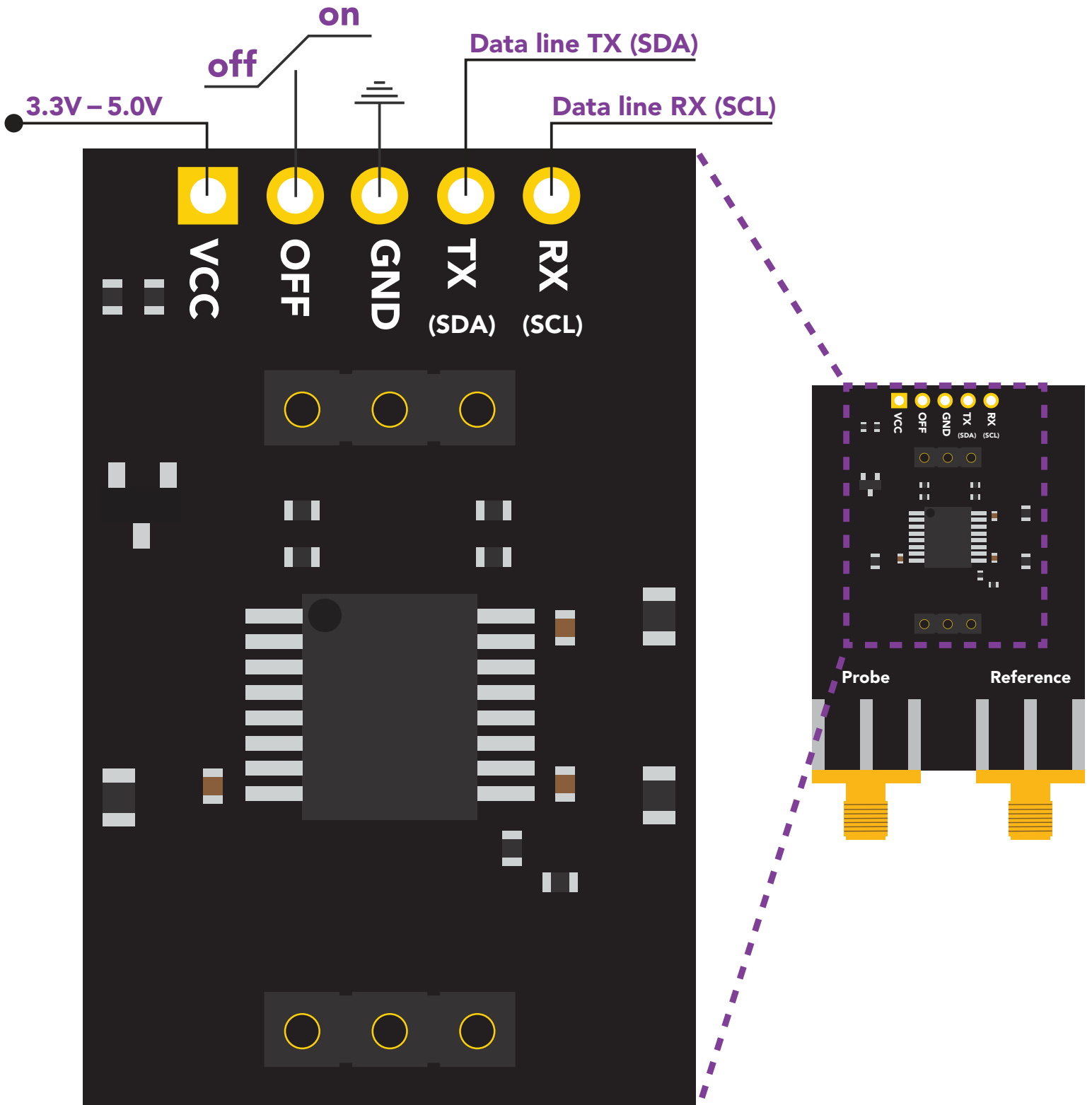

Data isolation

This schematic shows exactly how we isolate data and power using the [ADM3260](#) and a few passive components. The ADM3260 can output isolated power up to 150 mW and incorporates two bidirectional data channels.

This technology works by using tiny transformers to induce the voltage across an air gap. PCB layout requires special attention for EMI/EMC and RF Control, having proper ground planes and keeping the capacitors as close to the chip as possible are crucial for proper performance. The two data channels have 4.7kΩ pull up resistor on both the isolated and non-isolated lines (R1, R2, R3, and R4) The output voltage is set using a voltage divider (R5, R6, and R7) this produces a voltage of 3.9V regardless of your input voltage.

Isolated ground is different from non-isolated ground, these two lines should not be connected together.

VCC = 3.0v – 5.5v

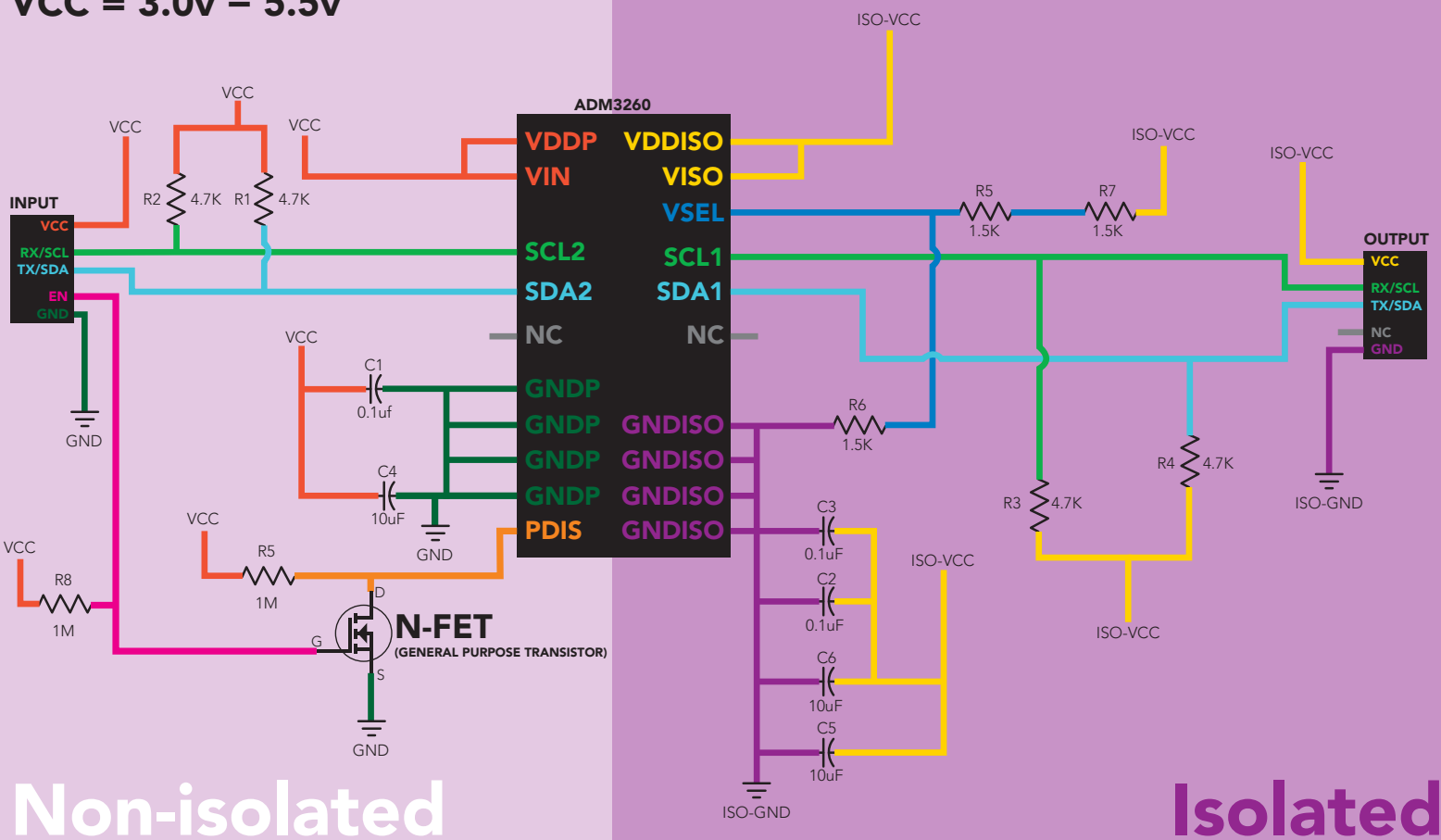

Non-isolated

Isolated